

Disc 09.C314.11

brembo
AFTERMARKET

Disc technical data

Axle Rear

Diameter
370 mm

Overall height (A)
69,1 mm

Centring diameter (B)
75 mm

Number of holes (C)
5

Thickness (TH)
24 mm

Minimum thickness
22,4 mm

Tightening torque 
Nm

Unit per box
1

EANCode
8020584224281

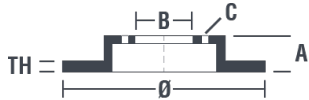

Brand part numbers

Brembo
09.C314.11

AP
25509 V

Breco
BV 9119

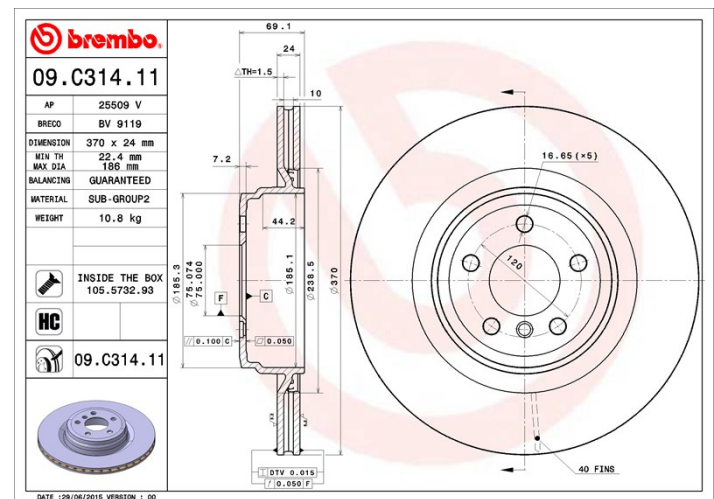

Technical specifications

High Carbon disc (HC)

Thanks to the high percentage of carbon in the chemical composition of the cast iron, the HC disc provides greater damping coefficient, able to reduce vibration and noise while driving.

HC

Disc with fixing screw

By supplying the fixing screw in the disc box, Brembo provides extra help to the mechanic if the original screw is rusty or worn to such an extent as to prevent or make it difficult to reuse.



UV Disc

The UV coating process provides a superior corrosion resistance and full disc protection.



Compatible vehicles

BMW

Model	Type	Kw	Year
5 Gran Turismo (F07)	550 i	330	07/12 02/17
5 Gran Turismo (F07)	550 i	298	10/09 06/12
5 Gran Turismo (F07)	550 i	300	08/09 06/12

5 Gran Turismo (F07)	550 i xDrive	300	07/12 03/14
5 Gran Turismo (F07)	550 i xDrive	330	07/12 06/13
5 Gran Turismo (F07)	550 i xDrive	300	06/10 06/12
7 (F01, F02, F03, F04)	750 d xDrive	280	07/12 12/15
7 (F01, F02, F03, F04)	750 i xDrive	300	09/09 06/12
7 (F01, F02, F03, F04)	750 i, Li	330	07/12 06/15
7 (F01, F02, F03, F04)	750 i, Li	300	09/08 06/12
7 (F01, F02, F03, F04)	750 i, Li xDrive	330	07/12 06/15
7 (F01, F02, F03, F04)	760 i	400	09/09 12/15
7 (F01, F02, F03, F04)	ActiveHybrid	342	09/09 06/12
7 (F01, F02, F03, F04)	ActiveHybrid	330	09/09 06/12

OE Part number

Compatible OE codes

BMW

34216775291