



BRAKE PAD

P 50 137

The P 50 137 brake pad is synonymous with reliability

The Brembo brake pad guarantees ultimate safety when braking thanks to the use of more than 100 different compounds, designed according to the type of vehicle and use. Stopping distances reduced to a minimum, maximum driving comfort and silent operation are the most important features of Brembo materials. Brembo brake pads are supplied together with an extensive range of accessories and assembly kits for professional-standard installation.

- ✓ OE-equivalent
- ✓ Brembo quality
- ✓ ECE-R90 certificate
- ✓ Safety
- ✓ Performance
- ✓ Comfort
- ✓ With accessories

Technical specifications

EAN code 8020584068397	Axle Front	Thickness 18 mm
Width 140 mm	Height 42 mm	Braking system Teves
Wear indicator Acoustic	WVA number 22626,25703	Accessories With accessories With anti-squeal shim With piston clip

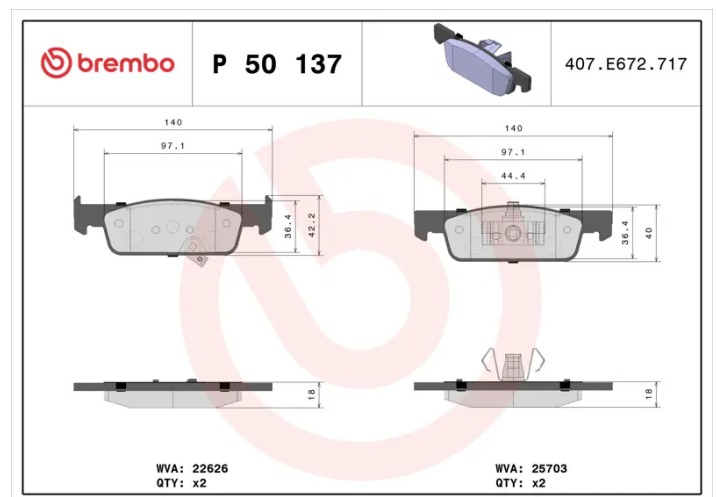

COMPATIBLE VEHICLES

COMPATIBLE OE PART NUMBERS

410603025R	RENAULT
------------	---------

4534211100	SMART
------------	-------

4534212100	SMART
------------	-------

A4534211100	SMART
-------------	-------

A4534212100	SMART
-------------	-------
