

## Datos técnicos pastillas

**Eje**  
Delantero

**WVA**  
24077

**Anchura**  
116,4 mm

**Espesor**  
19 mm

**Altura**  
63,7 mm

**Sistema de frenos**  
Lucas

**Accesorios**  
Con tornillos pinza freno  
Con accesorios

**Avisador de desgaste**  
Preparado

**Código EAN**  
8020584054260

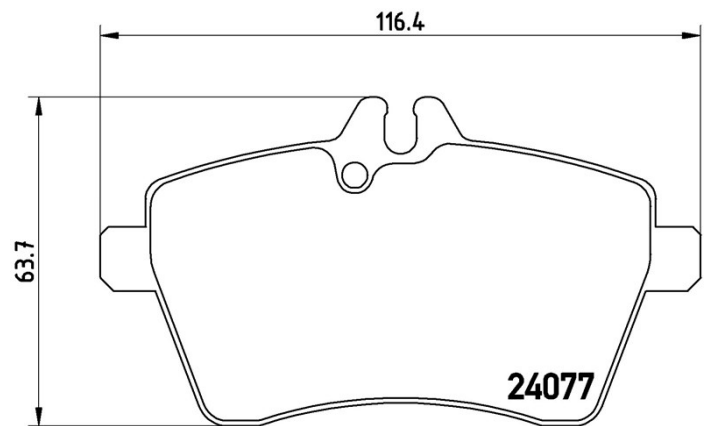
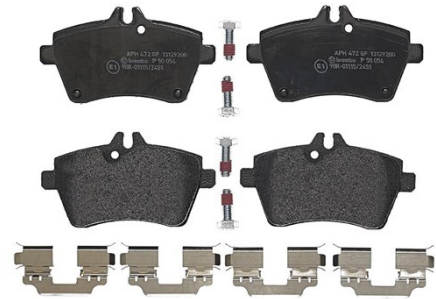

## Vehículos compatibles

### MERCEDES-BENZ

Modelo	Tipo	Kw	Año
A-CLASS (W169)	A 150 (169.031, 169.331)	70	09/04 06/12
A-CLASS (W169)	A 160 (169.031, 169.331)	70	04/09 06/12
A-CLASS (W169)	A 160 CDI (169.006, 169.306)	60	09/04 06/12

## Códigos OE

### Códigos OE compatibles

MERCEDES-BENZ	1694200220
MERCEDES-BENZ	1694201020
MERCEDES-BENZ	1694201820
MERCEDES-BENZ	1694202120
MERCEDES-BENZ	A1694200220
MERCEDES-BENZ	A1694201020

MERCEDES-BENZ

A1694201820

---

MERCEDES-BENZ

A1694202120

---