

Caractéristiques techniques des plaquettes

Essieu
Avant

WVA
24714, 24716, 24715

Largeur
147,6 - 216,6 mm

Épaisseur
15,9 mm

Hauteur
67,7 - 68,8 mm

Système de freinage
Delco Moraine

Accessoires

Témoin d'usure
Acoustique

Code EAN
8020584090343

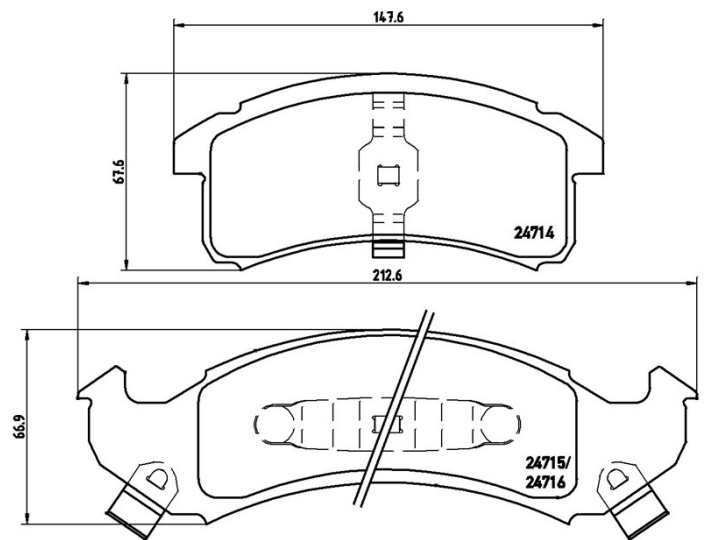

Véhicules couverts

BUICK				
Modèle	Type	kW	Année	
LESABRE	3.8	127	10/91 09/95	
LESABRE	3.8	153	10/95 09/99	
PARK AVENUE	3.8	127	01/91 10/96	
PARK AVENUE	3.8	150	10/94 10/96	
PARK AVENUE	3.8 Ultra	168	10/90 09/96	
RIVIERA Coupe	3.8	153	09/94 12/99	
CADILLAC				
Modèle	Type	kW	Année	
DEVILLE	4.5	134	09/89 12/90	
DEVILLE	4.6	205	09/96 09/99	

DEVILLE	4.6	224	10/93 09/99
DEVILLE	4.6 Concours	205	10/93 09/99
DEVILLE Coupe	4.9	149	09/90 12/93
ELDORADO Coupe	4.6	220	09/91 09/94
ELDORADO Coupe	4.6	224	09/94 09/02
SEVILLE (6K_)	4.6	224	10/93 09/97

CHEVROLET

Modèle	Type	kW	Année
CAMARO	3.4 V6	119	12/92 07/98
CAMARO	3.8	149	10/95 09/97
CAMARO	5.7 V8	205	12/92 07/98
CAMARO Convertible	3.4	119	10/92 09/95
CAMARO Convertible	3.8	149	10/95 09/97
CAMARO Convertible	5.7	207	10/92 09/97
CAMARO Convertible	5.7	205	10/92 12/95
LUMINA APV MPV	2.3	101	10/93 07/96
LUMINA APV MPV	2.3	108	12/92 07/96
LUMINA APV MPV	3.1	119	01/94 07/96
LUMINA APV MPV	3.1	90	08/89 07/96
LUMINA APV MPV	3.4	134	10/95 07/96
LUMINA APV MPV	3.8	123	10/91 09/95
LUMINA APV MPV	3.8	129	12/92 07/96

OLDSMOBILE

Modèle	Type	kW	Année
88 Saloon	3.8	153	09/91 12/99
SILHOUETTE	3.1	90	10/89 10/95
SILHOUETTE	3.8	127	10/89 10/95

PONTIAC

Modèle	Type	kW	Année
BONNEVILLE Saloon	3.8	127	09/91 09/95
BONNEVILLE Saloon	3.8	176	09/91 09/99
FIREBIRD	3.4	119	11/92 12/95
FIREBIRD	3.8	149	10/94 12/97
FIREBIRD	5.7	205	11/92 12/96

FIREBIRD Convertible	3.4	119	01/93 12/95
FIREBIRD Convertible	3.8	149	10/94 12/97
FIREBIRD Convertible	5.7	205	01/93 12/96
TRANS SPORT	2.3	101	01/93 03/97
TRANS SPORT	2.3	108	01/93 03/97
TRANS SPORT	3.1	90	07/89 03/97
TRANS SPORT	3.1	104	07/89 03/97
TRANS SPORT	3.8	112	07/89 03/97
TRANS SPORT	3.8	123	07/89 03/97
TRANS SPORT	3.8	127	07/89 03/97

Refs constructeur

Références constructeurs compatibles

BUICK	12510023
BUICK	12510042
CADILLAC	12510043
CHEVROLET	12370006
CHEVROLET	12510001
CHEVROLET	12510027
OLDSMOBILE	18022641
PONTIAC	18022641