



BRAKE PAD

P 50 151

The P 50 151 brake pad is synonymous with reliability

The Brembo brake pad guarantees ultimate safety when braking thanks to the use of more than 100 different compounds, designed according to the type of vehicle and use. Stopping distances reduced to a minimum, maximum driving comfort and silent operation are the most important features of Brembo materials. Brembo brake pads are supplied together with an extensive range of accessories and assembly kits for professional-standard installation.



- ✓ OE-equivalent
- ✓ Brembo quality
- ✓ ECE-R90 certificate
- ✓ Safety
- ✓ Performance
- ✓ Comfort
- ✓ With accessories

Technical specifications

EAN code 8020584115510	Axle Rear	Thickness 17 mm
Width 106 mm	Height 49 mm	Braking system CBI
Wear indicator Without	WVA number 22986	Accessories With accessories With anti-squeal shim With brake caliper bolts

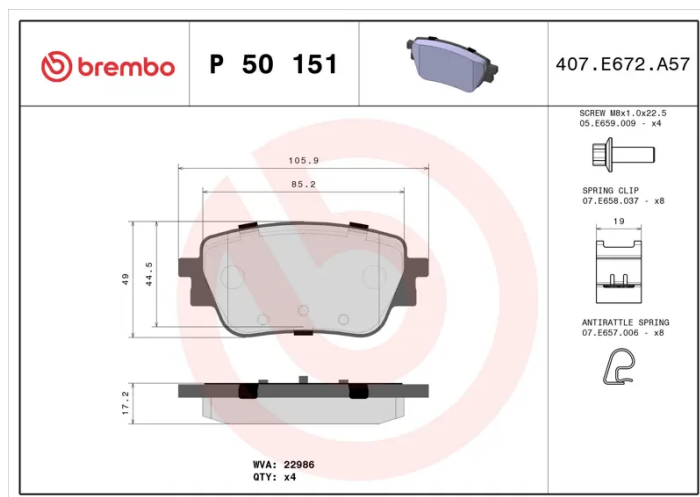

COMPATIBLE VEHICLES

COMPATIBLE OE PART NUMBERS

0004204502	MERCEDES-BENZ
------------	---------------

0004205203	MERCEDES-BENZ
------------	---------------

0004205703	MERCEDES-BENZ
------------	---------------

0004207500	MERCEDES-BENZ
------------	---------------

0004207700	MERCEDES-BENZ
------------	---------------

0004209905	MERCEDES-BENZ
------------	---------------

A0004204502	MERCEDES-BENZ
-------------	---------------

A0004205703	MERCEDES-BENZ
-------------	---------------

A0004205903	MERCEDES-BENZ
-------------	---------------

A0004207500	MERCEDES-BENZ
-------------	---------------

A0004207700	MERCEDES-BENZ
-------------	---------------

A0004209905	MERCEDES-BENZ
-------------	---------------