



BRAKE DISC PAINTED

09.D428.11

The 09.D428.11 painted brake disc is synonymous with reliability

The Brembo brake disc with special UV paint treatment guarantees superior corrosion resistance for the product, thanks to the protective coating on the outer edges and on the disc hub. The UV paint not only gives the disc a clean, shiny appearance but is also beneficial for the environment as the water-based UV paint treatment does not require the use of chemical solvents and is a low energy consumption process.

- ✓ OE-equivalent
- ✓ Brembo quality
- ✓ ECE-R90 certificate
- ✓ Safety
- ✓ High carbon
- ✓ Anti-corrosion
- ✓ Fastening screws



Technical specifications

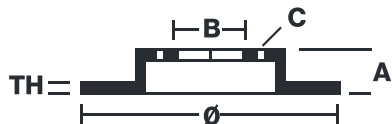

EAN code
8020584310236

Diameter \varnothing
305 mm

Thickness (TH)
25 mm

Height (A)
47 mm

Brake disc type
Ventilated

Centering (B)
69 mm

Number of holes (C)
5

Min. thickness
23,4 mm

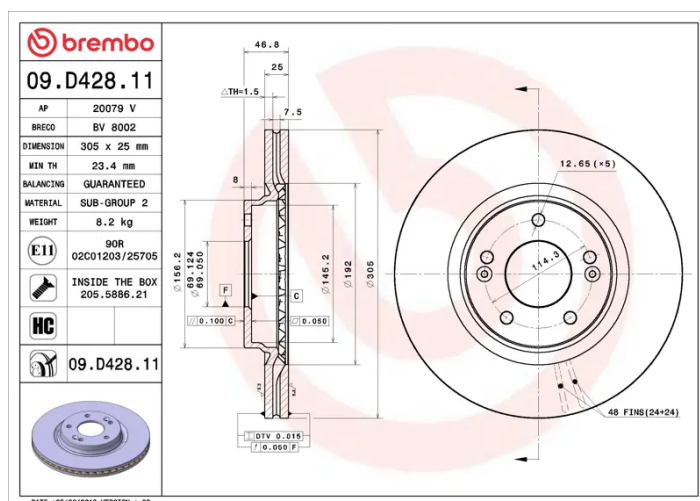

COMPATIBLE VEHICLES

COMPATIBLE OE PART NUMBERS

51712C1000	HYUNDAI
51712D7000	HYUNDAI
51712J9100	HYUNDAI
51712C1000	HYUNDAI (BEIJING)
51712C1000	KIA
51712C2000	KIA
51712D7000	KIA
51712J9100	KIA
551712D7000E	KIA
51712C1000	KIA (DYK)