



BRAKE PAD

P 11 017

The P 11 017 brake pad is synonymous with reliability

The Brembo brake pad guarantees ultimate safety when braking thanks to the use of more than 100 different compounds, designed according to the type of vehicle and use. Stopping distances reduced to a minimum, maximum driving comfort and silent operation are the most important features of Brembo materials. Brembo brake pads are supplied together with an extensive range of accessories and assembly kits for professional-standard installation.

- ✓ OE-equivalent
- ✓ Brembo quality
- ✓ ECE-R90 certificate
- ✓ Safety
- ✓ Performance
- ✓ Comfort



Technical specifications

EAN code 8020584060131	Axle Front	Thickness 18 mm
Width 183 mm	Height 55 mm	Braking system Bosch
Wear indicator Acoustic	WVA number 24164	Accessories With anti-squeal shim

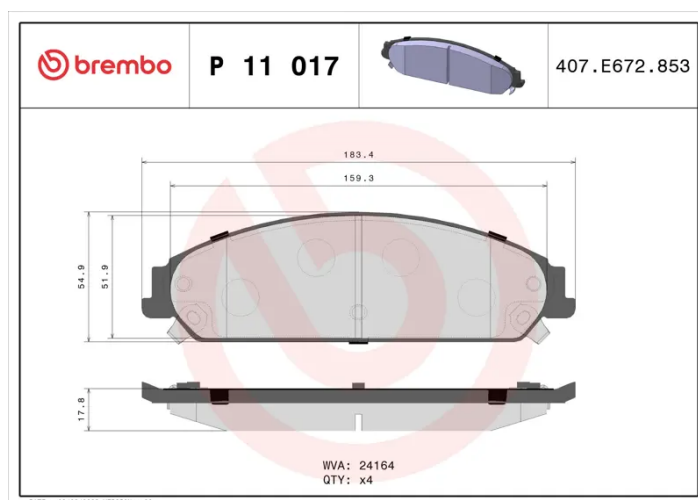

COMPATIBLE VEHICLES

COMPATIBLE OE PART NUMBERS

05137666AA CHRYSLER

05142558AA CHRYSLER

05142559AA CHRYSLER

05142559AB CHRYSLER

05175208AA CHRYSLER

5137666AA CHRYSLER

5142558AA CHRYSLER

5142558AD CHRYSLER

5142559AA CHRYSLER

5142559AB CHRYSLER

5175208AA CHRYSLER

K05142559AA CHRYSLER

K05142559AB CHRYSLER

5142558AD DODGE

68209532AA DODGE

68269953AA DODGE

K68269953AA DODGE

K05137666AA FIAT

K05142558AA FIAT

K05142559AA FIAT

K05142559AB FIAT

05142558AA LANCIA

K05137666AA LANCIA

K05142558AA LANCIA

K05142558AC LANCIA

K05142559AA LANCIA

K05142559AB LANCIA
