

## Specificații tehnice disc

**Osie** Anterioară

**Diametru**  
255 mm

**Înălțime totală (A)**  
46,2 mm

**Diametru de centrare (B)**  
55 mm

**Număr orificii (C)**  
4

**Grosime (TH)**  
22 mm

**Grosime min.**  
19 mm

**Cuplu de strângere**   
103 Nm

**Unități per cutie**  
2

**Cod EAN**  
8020584210710

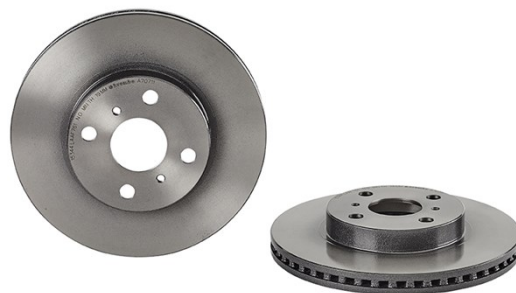
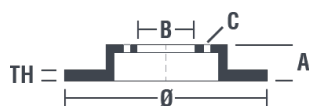

## Coduri mărci

**Brembo**  
09.A707.11

**AP**  
25256 V

**Breco**  
BV 8866

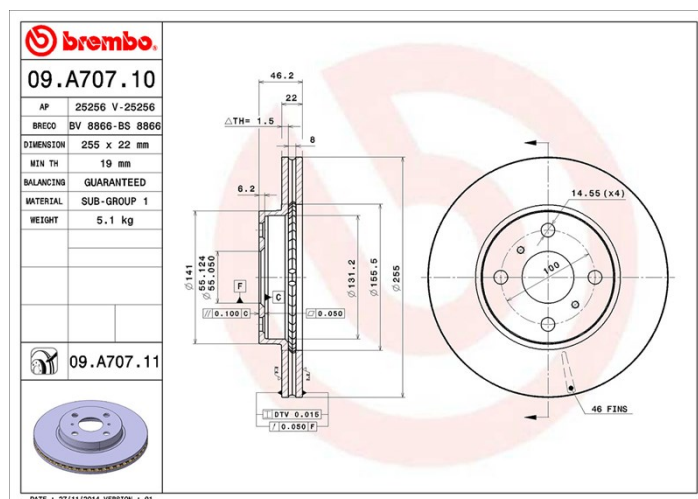

## Specificații tehnice

### Disc UV

Procesul de vopsire UV garantează o rezistență superioară la coroziune și o protecție completă a discului.



## Autovehicule compatibile

### TOYOTA

Model	Tip	kW	An
IQ (_J1_)	EV	47	09/12 12/15
PRIUS C (NHP10_)	1.5 Hybrid (NHP10)	54	12/11 -
YARIS (_P13_)	1.0 (KSP130_)	51	12/10 -
YARIS (_P9_)	1.0 GPL (KSP90_)	51	01/06 12/11
YARIS (_P9_)	1.0 VVT-i (KSP90_)	51	08/05 12/11
YARIS (_P9_)	1.3 VVT-i (NCP90_)	63	11/05 12/12
YARIS (_P9_)	1.3 VVT-i (SCP90_)	64	08/05 11/10

YARIS (_P9_)	1.33 VVT-i (NSP90_)	73	07/10 05/11
YARIS (_P9_)	1.33 VVT-i (NSP90_)	74	11/08 12/11
YARIS (_P9_)	1.4 D-4D (NLP90_)	66	08/05 12/12
YARIS (_P9_)	1.5 (NCP91_)	80	11/05 12/14

#### TOYOTA (FAW)

Model	Tip	kW	An
VIOS (_P15_)	1.3 (NSP150)	73	05/13 -
VIOS (_P15_)	1.5 (NSP151)	79	05/13 -

#### Coduri OE

##### Coduri OE compatibile

TOYOTA	435120D090
TOYOTA	4351252120