



BRAKE DISC PAINTED

09.9483.11

The 09.9483.11 painted brake disc is synonymous with reliability

The Brembo brake disc with special UV paint treatment guarantees superior corrosion resistance for the product, thanks to the protective coating on the outer edges and on the disc hub. The UV paint not only gives the disc a clean, shiny appearance but is also beneficial for the environment as the water-based UV paint treatment does not require the use of chemical solvents and is a low energy consumption process.

- ✓ OE-equivalent
- ✓ Brembo quality
- ✓ ECE-R90 certificate
- ✓ Safety
- ✓ Anti-corrosion



Technical specifications

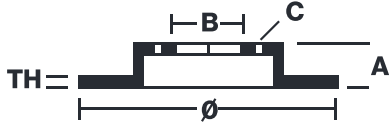

EAN code
8020584211922

Axle
Front and rear

Diameter Ø
256 mm

Thickness (TH)
24 mm

Height (A)
48 mm

Number of holes (C)
4

Brake disc type
Ventilated

Centering (B)
60 mm

Min. thickness
22 mm

Tightening torque
110 Nm

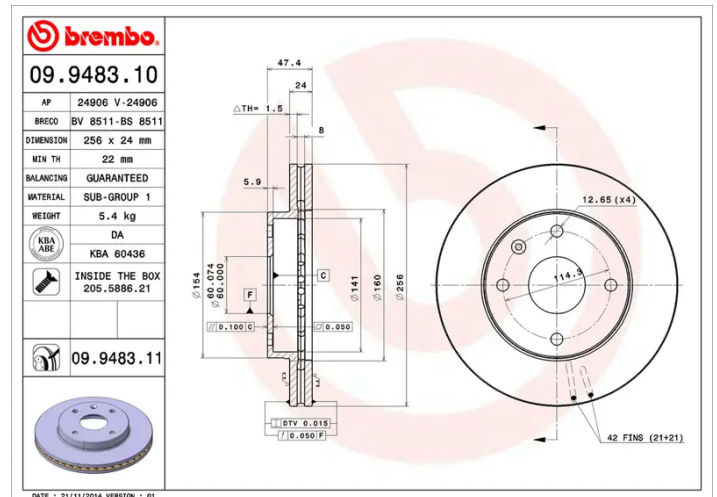

COMPATIBLE VEHICLES

COMPATIBLE OE PART NUMBERS

24537780 BAOJUN (SGMW)

9053332 BUICK (SGM)

96549782 BUICK (SGM)

96264591 CHEVROLET

96328338 CHEVROLET

96549782 CHEVROLET

J96415413 CHEVROLET

96264591 DAEWOO

96328338 DAEWOO

96549782 DAEWOO
